

## 8 LUTRON<sup>®</sup> ECOSYSTEM PROTOCOL

### 8.1 Protocol Specifications

EcoSystem technology is a control method for LEDs that provides addressing of individual fixtures and status feedback. This makes it easy to digitally assign one or many fixtures without complicated wiring. This opens up an entire suite of energy-saving, system-monitoring and system-control schemes where the design, setup and rezoning are all done within software, making the electrical and control design simple.

The Digital Control Adapter complies with Lutron proprietary specifications, including misswire protection.

The adapter can be configured for one or two EcoSystem channels. "Single Channel" Ecosystem is used for DDM (Dim control only) and "Two Channel" Ecosystem is used for CTM (one channel for Dim control and one for color/CCT). The araya<sup>5</sup> modules attached to different interface boards can be controlled independently or assigned to a single group by the EcoSystem controller.

The EcoSystem control is responsible for saving any configuration settings. Once an interface board is assigned a pair of addresses, assigned addresses are saved in NVRAM. During the EcoSystem discovery process, the user pairs the desired dimming control in the controller to the Dim channel address in the interface board. The same applies for the CCT channel.

- 1 pair 16AWG Eco Loop, 900 feet.
- Maximum of 64 addresses on each loop.

#### EcoSystem Control Systems (recommended list)\*

Quantum System

HomeWorks QS

Grafik Eye QS Control Unit with EcoSystem

EnergiSavr Node with EcoSystem

Power Module with EcoSystem

PowPak RMJ-ECO-32-DV-B

\*Recommendations are subject to change. Consult your Lumenetix representative for the most updated list.

### EcoSystem Controller Example

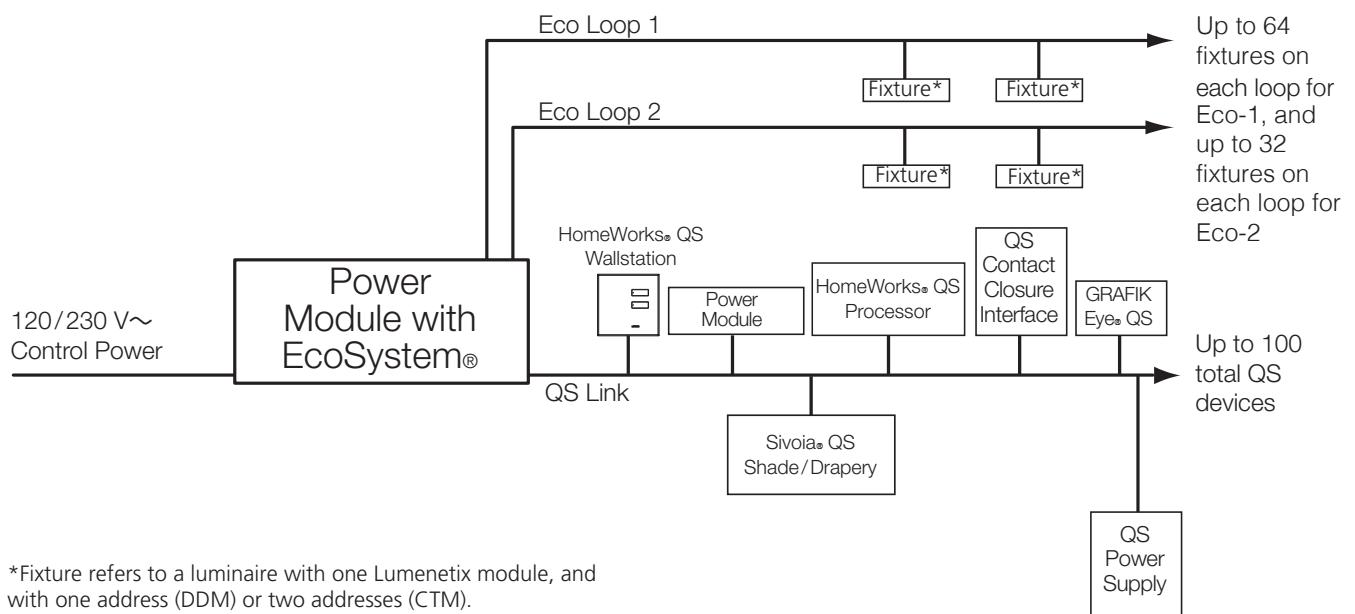

## 8 LUTRON<sup>®</sup> ECOSYSTEM PROTOCOL

### 8.2 Eco Wiring

- EcoSystem Digital Loop can be wired as Mains voltage or IEC PELV/NECR Class 2 for maximum wiring flexibility..
- The Loop is polarity insensitive and can be wired in any topology..
- Consult all national and local electrical codes for separation requirements..

Wire Gauge	Maximum EcoSystem-Compliant Loop Wire Length
4.0 mm <sup>2</sup> (12 AWG)	671 m (2200 ft)
2.5 mm <sup>2</sup> (14 AWG)	427 m (1400 ft)
1.5 mm <sup>2</sup> (16 AWG)	275 m (900 ft)
1.0 mm <sup>2</sup> (18 AWG)	175 m (570 ft)

### Drain Wire Connections

Drain wire connections are required as follows.

#### Shielding

To add another level of protection from electromagnetic noise, a grounded shield is added over the twisted pair wires. When this is enclosed in a protective jacket, to avoid ground loops and electromagnetic contamination of the ground system, all control ground wiring, including cable shields and drain wires, should be treated like sensitive current-carrying conductors. All control ground wires should be insulated (not bare) and the same wiring practices should be observed with ground wires as with other sensitive signals. Care must also be taken when designing control wiring to ensure that each shield is connected to only a single ground point. You should establish this point at a central location, like a control panel or cabinet, and avoid all connection to grounds in the field. A control ground is sometimes referred to as an isolated ground (an oxymoron) for this reason, but the term single-point ground is more accurate.

#### Method-1

A typical two-pair shielded cable can be prepared for termination to the terminals with the drain wire cut off. This is usually done at the field end of the cable where no shield grounding is desired. You will then use insulating tape or heat-shrink tubing to protect the cable from contamination and to prevent accidental grounding of the shield or drain wire. An accidental ground at this point would almost certainly create an undesirable ground loop.

#### Method-2

A typical two-pair shielded cable can be prepared for termination to the terminals with the drain wire cut off. The drain wire, which is an uninsulated conductor, is sleeved with a insulating tubing to prevent accidental grounding. The crimp-on lug is valuable in this instance to retain the tubing. Insulating tape or heat-shrink tubing is again used to protect the cable from contamination and to prevent accidental grounding, since any accidental connection between the drain wire and a chassis, frame, or enclosure would almost certainly create a ground loop.